

CAST IRON SUBMERSIBLE SUMP PUMPS

MCI033/MCI050

The Myers[®] MCI033 and MCI050 are rugged cast iron sump pumps featuring a vortex impeller that provides solids-handling capability up to 1/2". Product is available in 1/3 HP and 1/2 HP, 115 Volt single phase 60 Hz. Pump discharge is 1-1/2" NPT. 2-pole float switch for minimum 10" diameter sumps.

APPLICATIONS

Basement sumps, dewatering, light effluent, water transfer

SPECIFICATIONS

- Capacities – MCI033 - 48 GPM (182 LPM)
MCI050 - 62 GPM (235 LPM)
- Shut-off Head – 24' (7.3 m)
- Operation – On: 9" (229 mm)
Off: 4" (102 mm)
- Operation – Automatic
- Solids Handling – 1/2" (12.7 mm)
- Liquids Handling – Drainage effluent
- Continuous Liquid Temperature – 130°F (54°C)
- Motor Electrical Data – 1/3 HP, 9.8A; 1/2 HP, 12A; shaded pole with thermal overload protection, 115V, 1Ø, 60Hz, 1550 RPM
- Acceptable pH Range – 6-9
- Shaft Seal – Carbon and ceramic
- Housing/Volute – Heavy cast iron
- Volute Base – Fiberglass reinforced polypropylene
- Impeller – Fiberglass-reinforced Noryl[®] with threaded brass insert
- Exterior Hardware – Stainless steel
- Power Cord – 10' (3 m), 16/3, SJTW-A, SJTW
- Discharge, NPT – 1-1/2" (50.8 mm)
- Min. Sump Diameter – 10" (25.4 cm)



FEATURES

Easy Fit

2-pole switch design allows for operation in sump diameters of 10" or more

Reliable and Tough

Rugged, oil-cooled motor provides continuous bearing lubrication and maximizes heat dissipation

Extended Service

Lubricated ball bearings and shaft seal for longer service life

Eliminates Failures

Shaded pole motor eliminates failure-prone switches and relays

Motor Protection

Long-life carbon/ceramic seal protects motor against water leakage

Thermal Overload

Heat sensor overload protection with automatic reset when motor cools to safe operating temperature

No Drilling Required

Anti-airlock hole in base reduces added labor

Easy Serviceability

Pump, intake screen volute base, switch and power cord are serviceable

ORDERING INFORMATION

Catalog Number	HP	Volts	Phase/Cycles	Amps	Discharge Size	Switch Type	Cord Length	Approx. Wt. Lbs.
MCI033	1/3	115	1/60	9.8	1-1/2"	2-pole	10'	24
MCI050	1/2	115	1/60	12	1-1/2"	2-pole	10'	26

In order to provide the best products possible, specifications are subject to change. Myers[®] is a registered trademark of Pentair Water.



Myers[®]

Pentair Water

CAST IRON SUBMERSIBLE SUMP PUMPS

DIMENSIONS

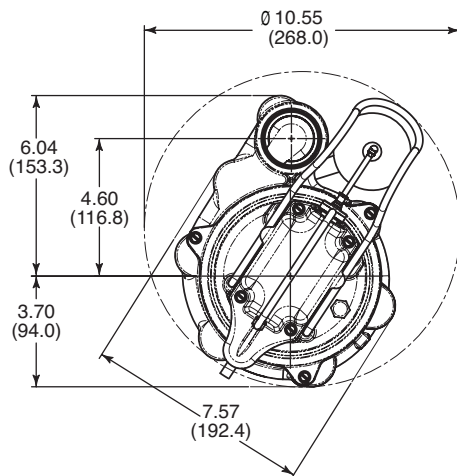
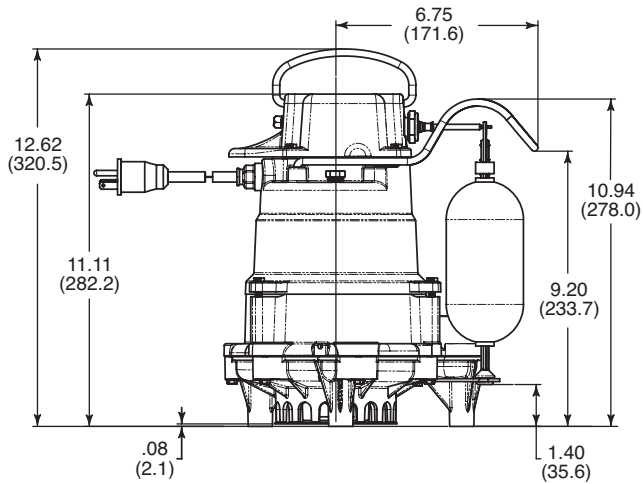

PUMP PERFORMANCE

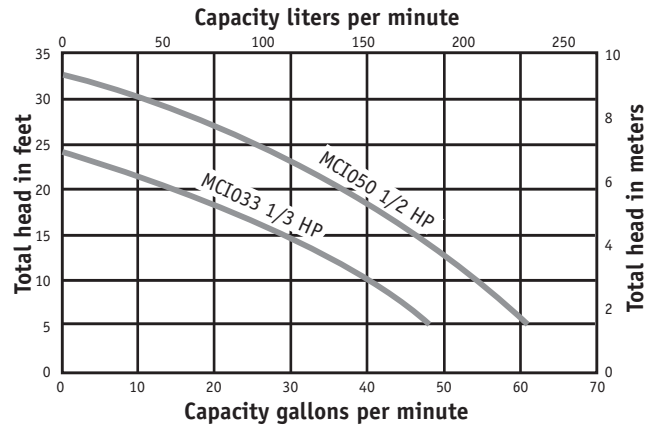

Myers | Customer Service: 888.987.8677 | Fax Orders: 888.840.7867 | www.myerspump.com | Form No. M9209SSE (07/10)

Canada | Phone: 519.748.5470 | Fax: 519.748.2553