

Top View

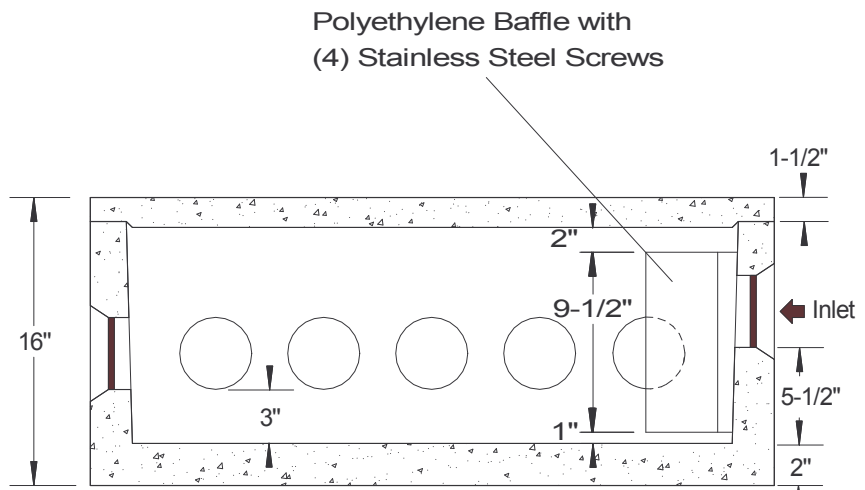

Side View

Polyethylene Baffle with
(4) Stainless Steel Screws

SPECIFICATIONS	
<p>Concrete Min. Strength: 4,000 psi at 28 days Reinforcement: Fiber, 10ga. wire mesh Air Entrainment: 5% Pipe Connection: Polylok Seal (patented) Load Rating: 300 psf Weight = 325 lbs</p>	<p style="text-align: center;">PRECAST DISTRIBUTION BOXES MODEL DB-12 / 12 OUTLETS W/BAFFLE</p> <p style="text-align: center;">Woodard's Concrete Products, Inc. 629 Lybolt Road, Bullville, NY 10915 (845) 361-3471 / Fax 361-1050</p>