

## Oil Trap Tank for buildings up to 5,500 sf - traffic rated

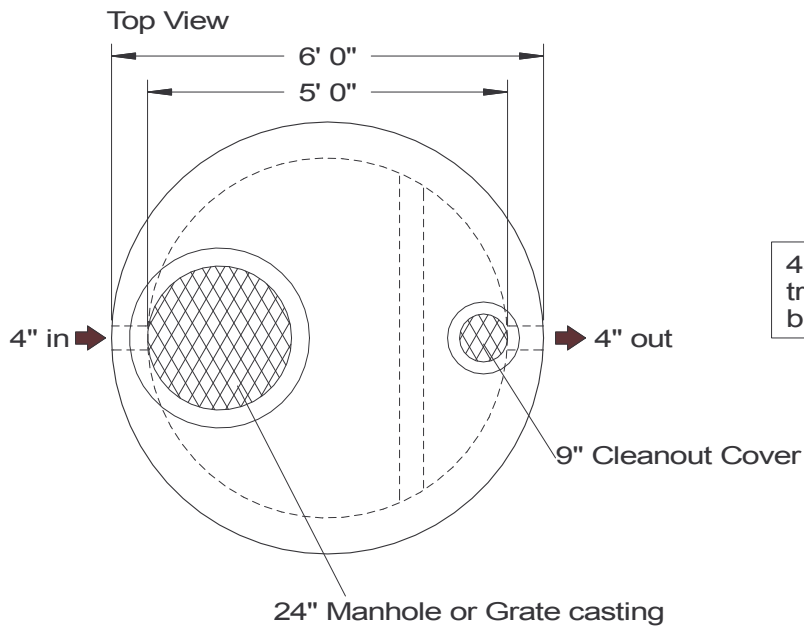

450 gallon capacity can treat floor drains for a building up to 5,500 sf.

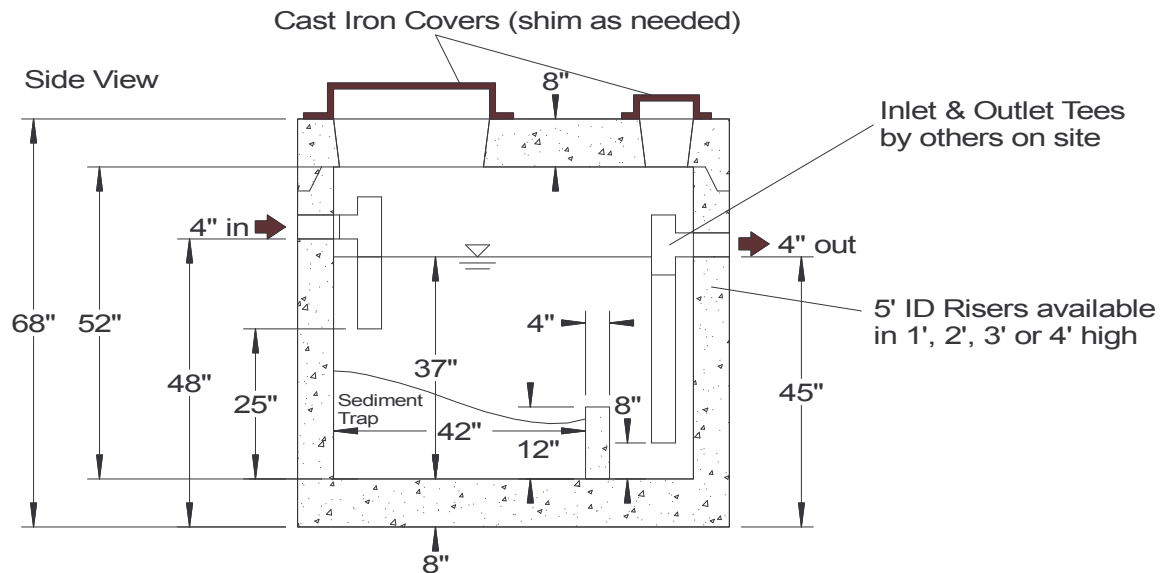

| SPECIFICATIONS   | OIL / WATER SEPARATOR<br>Model OWS-5<br>450 Gallons   |
|--|---|
| Concrete Min. Strength: 4,000 psi at 28 days<br>Reinforcement: 3x12 W3xW2.1 / ASTM C478<br>Air Entrainment: 6%<br>Construction Joint: Butyl Rubber Sealant<br>Pipe Connection: 4" Rubber Boots<br>Load Rating: HS-20 traffic rated<br>Weight = 9,000 lbs | <b>Woodard's Concrete Products, Inc.</b><br>629 Lybolt Road, Bullville, NY 10915<br>(845) 361-3471 / Fax 361-1050<br><br>Page 10C    2/4/10 |