

Plan View

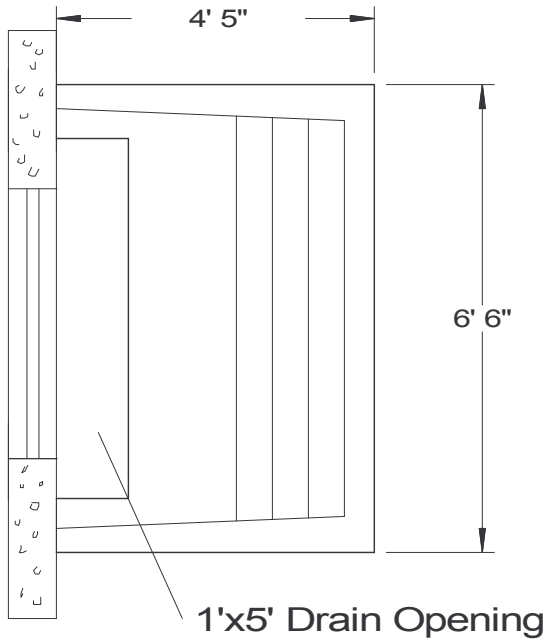

Section

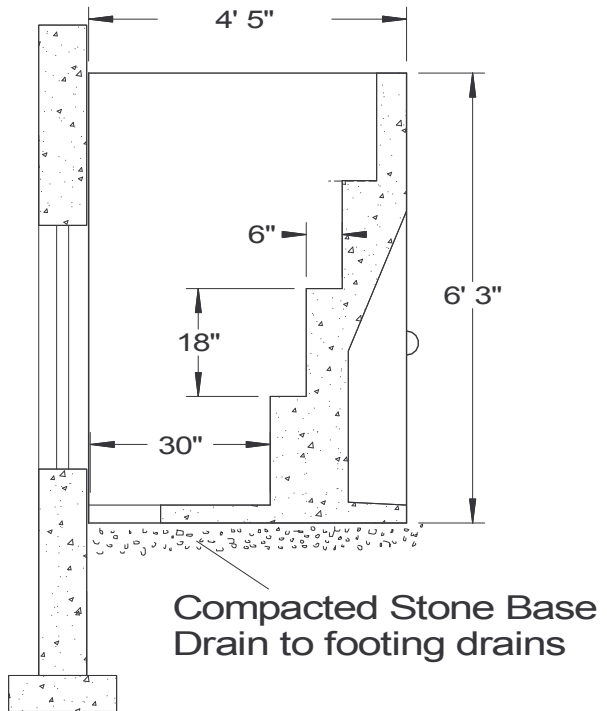

SPECIFICATIONS

Concrete Minimum Strength: 4,000 psi at 28 days
Reinforcement: #4 Rebar / ASTM A615
Air Entrainment: 5%

Weight = 9,000 lbs
Load Rating = 300 psf

PRECAST WINDOW WELL

Woodard's Concrete Products, Inc.
629 Lybolt Road, Bullville, NY 10915
(845) 361-3471 / Fax 361-1050